

Features

- RFC 1321 compliant MD5
- >500 Mbps performance
- Higher performance available
- 32-bit data input port
- Full width message digest output
- Portable to any technology library
- Easy integration into any SoC design

Benefits

- Full-width data ports maximize performance, minimize latency
- Fast delivery for accelerated time to profit

Applications

- Encrypted data storage
- Secure communications
- Secure processing
- IPsec acceleration
- SSL acceleration
- E-commerce
- VPN
- Financial Transactions



MD5-A100 **Message Digest 5**

The Athena Group delivers the Message Digest 5 (MD5) as a semiconductor intellectual property (IP) core. Athena's MD5-A100 MD5 core complements Athena's leading-edge TeraFire public key (PK) cryptography accelerators. Whether your application demands MD5 performance or the power savings of a dedicated core, Athena's MD5-A100 core delivers. The MD5-A100 is compliant with RFC 1321 and can accept data input rates greater than 500 Mbps.

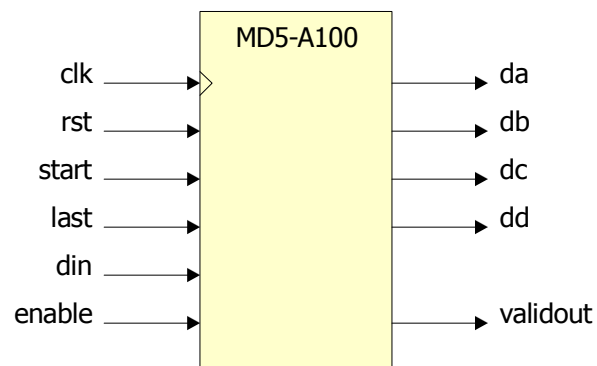

Figure 1: Block Diagram of MD5-A100

Product Description

The MD5-A100, shown in Figure 1, is a fully synchronous design and features a 32-bit data input port, and full width message digest output for maximum throughput and minimum latency. A data valid output is provided to simplify retrieval of the message digest.

Each MD5-A100 core is delivered as a firm core optimized to any customer-specified library. The package includes the core, verification suites, timing and simulation models, and documentation.

Athena's IP cores are designed for efficient implementation and rapid delivery. The company's proprietary, wholly automated implementation and verification methodology produces synchronous, testable IP cores of the highest quality. All Athena IP cores achieve a score of 95% or better on the OpenMore scale of IP reusability.

About The Athena Group, Inc.

Based in Gainesville, Florida, Athena innovates breakthrough technologies that achieve the optimum balance of power, performance, and silicon area in a wide range of applications such as wireless, satellite, and secure communications. Athena provides patented semiconductor intellectual property (IP) solutions, with products ranging from the market-leading TeraFire® security cores, to Atomic DSP™ cores, and Atomic SDR™ software defined radio cores.

Athena was founded in 1986 and is privately held.



The Athena Group, Inc.
408 W. University Ave., Suite 306
Gainesville, FL 32601

Phone: (352) 371-2567
Toll-free: (800) 741-7440
Fax: (352) 373-5182
www.athena-group.com

Copyright The Athena Group, Inc., 2008. All rights reserved. Reproduction in whole or in part is prohibited without the prior written consent of the copyright owner. The information presented in this document does not form part of any quotation or contract, is believed to be accurate and reliable, and may be changed without notice. No liability will be accepted by the publisher for any consequence of its use. Publication thereof does not convey nor imply any license under patent or other industrial or intellectual property rights.
